

Dimensions | Elevation & Plan View

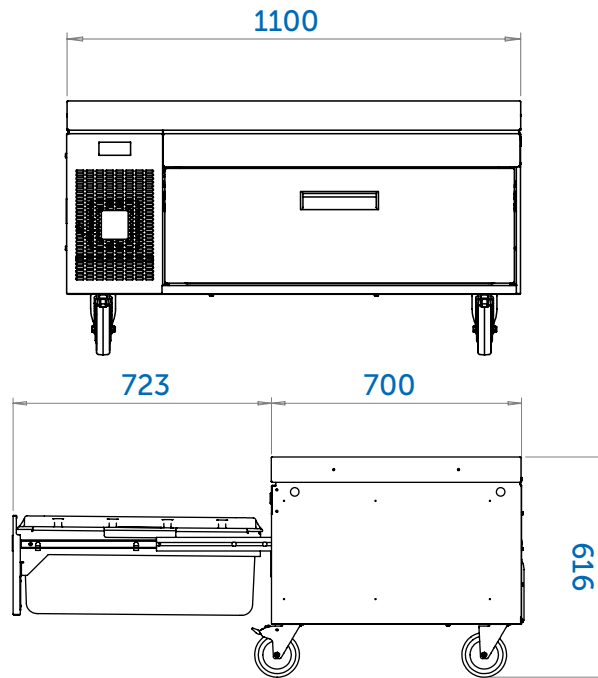

Fridge to Freezer.
Each drawer is switchable in minutes. Accurate and stable at any temperature. (-22°C to +15°C)

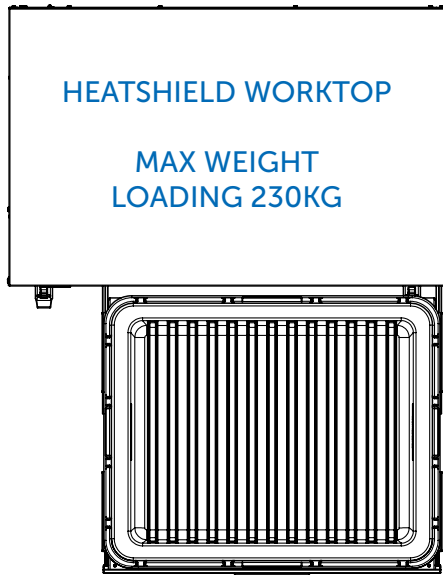

Storage Capacity Per Drawer
4 x 1/1 GN Pans
100 mm Deep or equivalent

Chef Bases with heat shield (HS) worktops are designed to accommodate hot cooking equipment, and withstand temperatures up to 200°C

Chef Bases can be supplied with a variety of castors and rollers to achieve specific worktop heights and cooking equipment weight loadings

These units can also be fitted with fixed frames (FF) where a particular worktop finished height between 590 and 900 mm is required

Dimensions for VCS1/HCHS

OPTIONS

Top and Base | Worktops and Castors

(HS) - protects unit tops exposed to temperatures up to 200°C



	High Castors		Standard Castors		Locking Roller Base		Small Locking Rollers		Fixed Frame	
Finished Height & Load Bearing Weight with Heat Shield (HS)	616 mm	VCS1/HCHS	545 mm	VCS1/CHS	501 mm	VCS1/RHS	491 mm	VCS1/SRHS	590-900mm	VCS1/FFHS
	235 kg		300 kg		285 kg		285 kg		235kg	
	(R1) REFRIGERANT R404A									
	(R2) REFRIGERANT R600a									
	(BC) BLAST CHILL AVAILABLE									

CLIMATE TESTING: Tested to Climate Class 4 (30°C and 55% relative humidity) for temperature and energy consumption

Tested to Climate Class 5 (40°C and 40% relative humidity) for temperature

MAINS: 230 Vac 50 Hz also 60 Hz available

Applications

- Bulk storage at point-of-use
- Chef Base plus standard Heat Shield
- Choice of worktop heights
- Robust equipment drawers
- In-range cassette drawer
- Holds set temp point in hot kitchens
- Hot or Cool cookline applications

Operational Benefits

- Flexibility: works as fridge or freezer
- Blast chiller option also available
- Reliable: amazing temperature stability
- Green: extremely energy efficient
- Cuts food wastage
 - » Food does not dehydrate
 - » No freezer burn or ice crystals
 - » No condensation on the food
- Ergonomically efficient
- Minimal maintenance costs
- Quick and easy to clean
- Robust and reliable

ADANDE® in the Cookline (VCS)



VCS R1
R404A

VCS R2
R600a

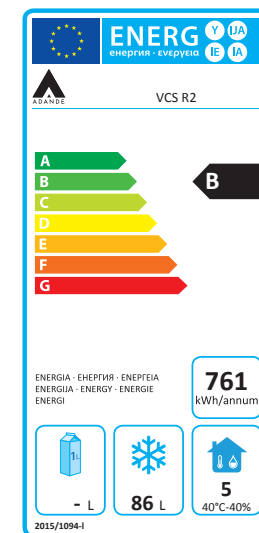
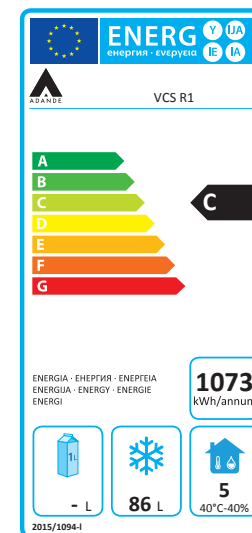

Tested independently!

The new EU Eco Design regulation will ensure that newly produced professional refrigerators and freezers will have to fulfil minimum energy efficiency requirements as of 1st July 2016. This will make understanding energy efficiency much simpler for consumers and will accelerate the growing shift in the market toward sourcing more energy efficient products